

ALLIGHTSYKES

SYKES CP220i

Technical Pack

Rev1 Dec2017



JAMES RIVER
EQUIPMENT



LIGHT



WATER



POWER

SYKES CP220i - Pumpend

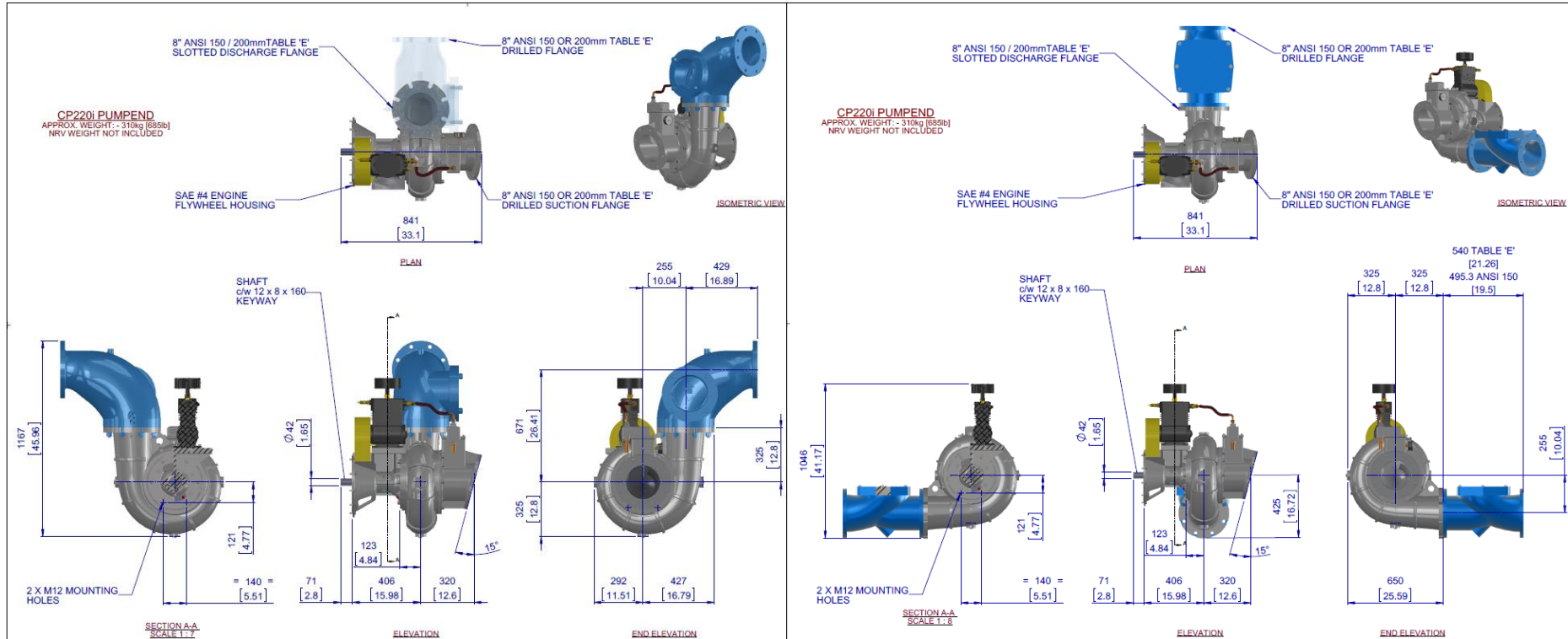

SYKES CP220i - Pumpset

DRY WEIGHT: 1850KG [4079lb]
FUEL CAPACITY: 440L [116 US GALLON]

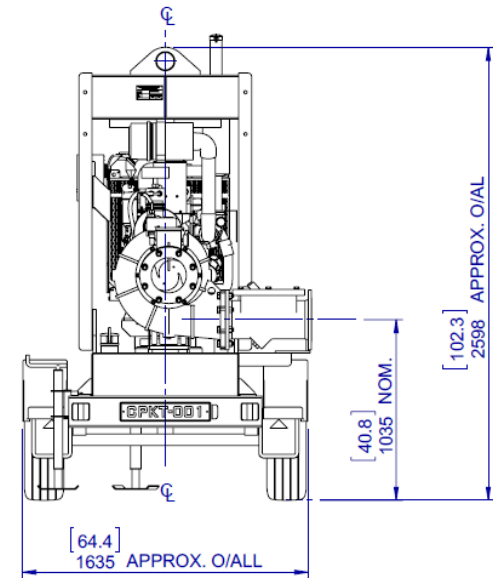
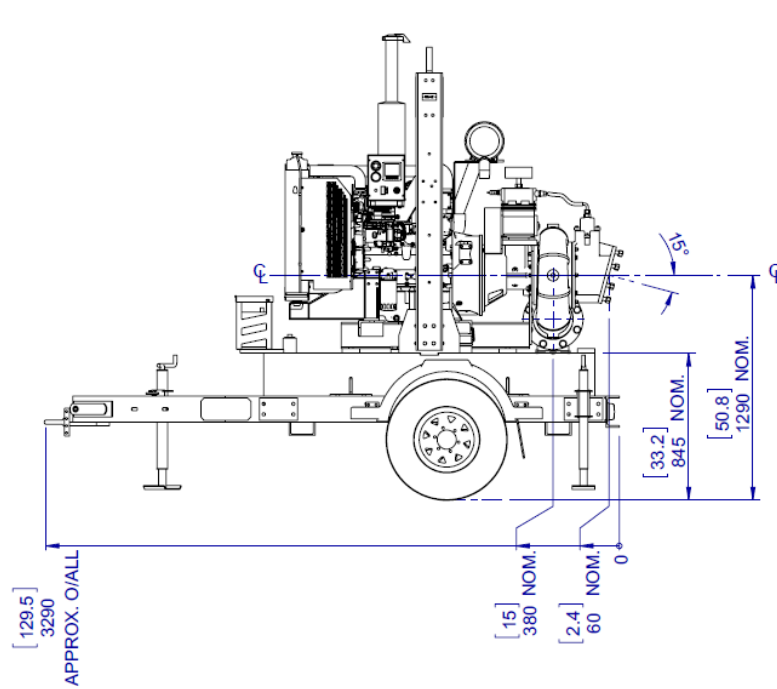

CP220i Performance Curve

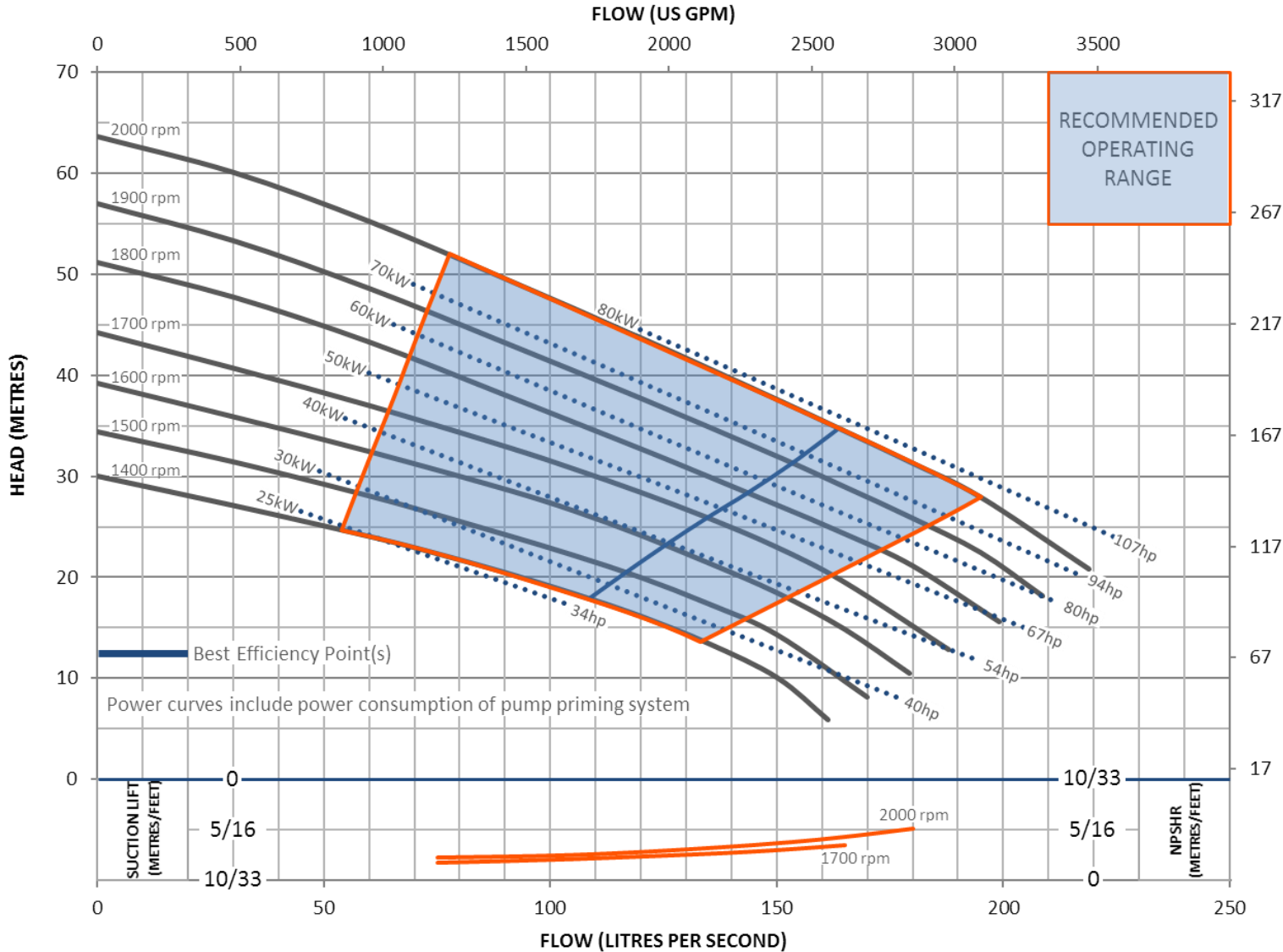

WATER

PUMPEND:

CP220i

IMPELLER DIA:

320mm / 12.60"

SOLID HANDLING SIZE:

80mm / 3.15"

SUCTION SIZE:

200mm / 8"

DISCHARGE SIZE:

200mm / 8"

Revision: 2 15-02-17

SYKES

¹Performance to AS2417/SO9906 Grade 2 for clear, cold (15°C) water at sea level. Other liquids may require performance adjustments.

²Performance curves do not include discharge check or non return valve losses.

Design Details			Material Data					
Single Stage, End Suction type, 2 vane open impeller, single volute, centrifugal pump			Standards		AUSTRALIAN		AMERICAN	
			Materials of Construction	<i>Material</i>	<i>Grade</i>	<i>AS</i>	<i>Grade</i>	<i>ASTM</i>
Suction Flange	200 8	mm Inch	Tee Piece	SG IRON	400/12	1831	65-45-12	A536
Delivery Flange	200 8	mm Inch	Front Adaptor Plate	N/A				
Solids Handling Size	80 3.2	mm Inch	Pump Casing (Volute)	SG IRON	400/12	1831	65-45-12	A536
Maximum Head	64 210	m Ft	Front Wear Plate	Stainless	316/H6B	2074	CF8M	A351
Maximum Capacity	220 3,485	L/sec USPM	Impeller	Stainless	316/H6B	2074	CF8M	A351
Engine Adaptor	SAE	#4	Rear Wear Plate	Stainless	316/H6B	2074	CF8M	A351
Shaft Diameter	40 1.58	mm Inch	Rear Adaptor Plate	N/A				
Fuel Rate @ BEP 1,800rpm Duty	13.84 3.66	L/hr USGAL/hr	Pump Shaft	Stainless	431	2837	431	A276-98b
			Bearing Bracket	SG IRON	400/12	1831	65-45-12	A536
			Bearing Covers	SG IRON	400/12	1831	65-45-12	A536
			Mechanical Seal	Multi spring balanced mechanical seal assembly with silicon carbide /silicon carbide mechanical seal faces, in self contained oil reservoir				